

Super Compact Load Cell



A DADCO Super Compact Load Cell may be used to check the internal pressure of a DADCO Super Compact Nitrogen Gas Spring and quickly determine if the gas spring is charged to the desired pressure.

Operating Instructions

1. Position the DADCO Super Compact Load Cell with its counterbored base on top of the gas spring.
2. Place both the load cell and gas spring beneath a DADCO Portable Test Stand (90.305.3), an Arbor press or another press.
3. **Apply the load to the gas spring, depressing the gas spring rod only 2 mm** (additional travel may damage the load cell) and read the gauge on the front of the load cell. The gauge reflects the precise pressure inside the spring. Reading should not exceed 2175 psi (150 bar).

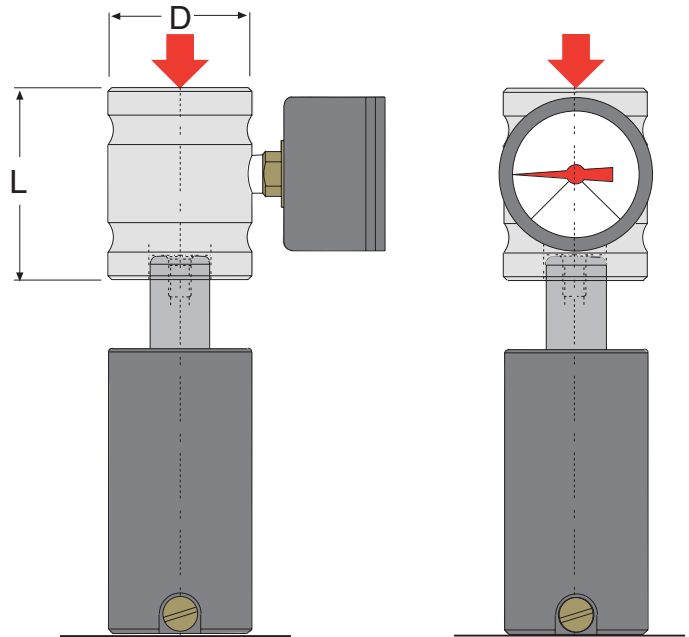

Side and front views of a DADCO Super Compact Load Cell in testing position on top of a DADCO Super Compact Nitrogen Gas Spring.

Determining Force

To determine the force (F) that a DADCO Super Compact Nitrogen Gas Spring will deliver at the start of the stroke, use one of the following formulas:

$$F \text{ (lbs.)} = A \text{ (in}^2\text{)} \times P \text{ (psi)}$$

U.S. Customary Unit Example:

If testing an SC.01000 gas spring at 2000 psi, the force would be calculated as follows:

$$1.097 \text{ in}^2 \times 2000 \text{ psi} = 2194 \text{ lbs.}$$

$$F \text{ (N)} = A \text{ (cm}^2\text{)} \times P \text{ (bar)} \times 10$$

Metric Example:

If testing an SC.01000 gas spring at 150 bar, the force is calculated as follows:

$$7.08 \text{ cm}^2 \times 150 \text{ bar} \times 10 = 10620 \text{ N or } 10.62 \text{ kN.}$$

DADCO Super Compact Gas Spring Model*	DADCO Load Cell	Rod Dia. mm/in	Piston Area (A) cm ² /in ²	D mm/in	L mm/in
SC.00740	90.300.0750	20 0.79	4.91 0.761	38 1.50	51 2.00
SC.01000 / 98.80.01000	98.300.01000	20 0.79	7.08 1.097	48 1.89	55 2.17
SC.01800 / 98.80.01800	98.300.01800	30 1.18	12.59 1.517	59.9 2.36	60 2.26
SC.03500	98.300.03500	45 1.77	21.24 3.292	66.7 2.63	65 2.56
SC.04700 / 98.80.04700	98.300.04700	50 1.97	31.19 4.834	74.9 2.95	65 2.56
SC.07500 / 98.80.07500	98.300.07500	63 2.48	50.31 7.798	95 3.74	65 2.56
SC.11800 / 98.80.11800	98.300.11800	80 3.15	78.60 12.183	119.9 4.72	70 2.76
SC.18300 / 98.80.18300	98.300.18300	100 3.94	122.78 19.031	150.1 5.91	75 2.96

*For information on DADCO's Standard Load Cells for use with DADCO's Mini, **Ultra Force**[®], SCR and Large Series Nitrogen Gas Springs contact DADCO and request bulletin 97B119G.

Rebuild (Gauge Replacement) Instructions

NOTE: Order the appropriate replacement gauge. For questions on which gauge to order reference DADCO's Gauge Bulletin #B00128D.

1. Remove the flush plug 90.505.110 (G-109) and set aside for reassembly (Fig. 1).
2. Empty the oil out of the body and wipe with a lint-free cloth.
3. Unthread the old gauge and discard.
4. Apply Teflon Tape to the new gauge thread. Ensure that the tape does not cover the access hole.
5. Thread the gauge onto the body (lettering should be right-side-up).
6. Fill the body with oil up to the base of the flush plug, note the fill line (Fig. 2).
7. Install the Flush Plug 90.505.110 (G-109), and watch for needle movement on the gauge, if movement occurs, stop and remove a small quantity of oil with an eye dropper. Repeat this step until the flush plug is installed with no needle movement.
8. Test the new gauge by using it on the appropriate spring with a known pressure, see Operating Instructions on reverse.



Figures

